

## Roto Casement

---

- Section Details : Operating/Stationary, 4 9/16" Jamb, Contemporary Sash
- Section Details : Operating/Stationary, 4 9/16" Jamb, Traditional Sash
- Section Details : Big Bottom Rail
- Section Details : Sash Profiles & SDL Options
- Section Details : Mull Sections
- Section Details : Sill Options
- Section Details : Frame Options
- Section Details : Exterior Trim Options
- Section Details : Screen Options
- Section Details : Nail Fin Options

# Roto Casement

## Section Details : 4 9/16" Jambs

Contemporary Sash  
Square Detail

SCALE: 3" = 1'-0"

### Operating

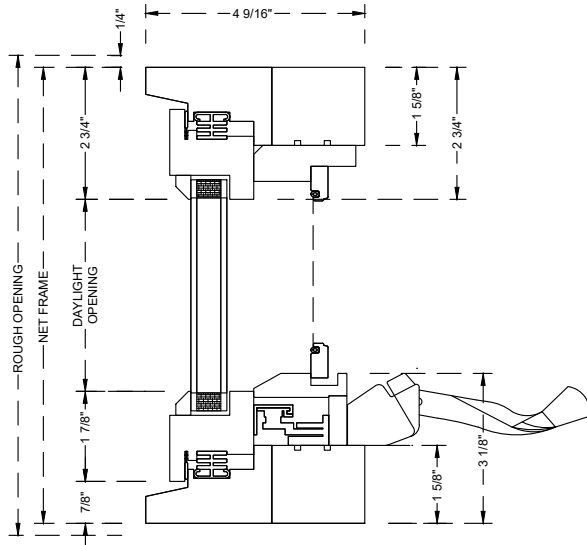

Head Jamb & Sill

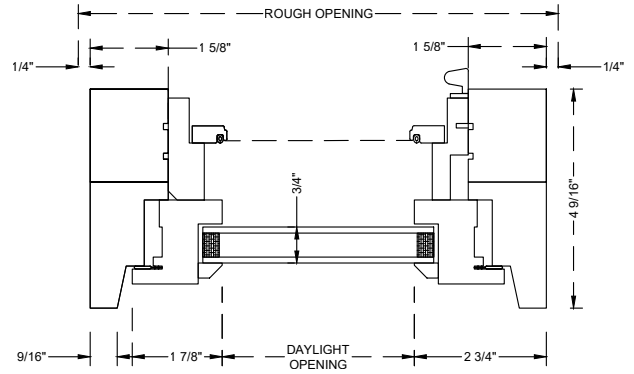

Jambs

### Fixed Sash

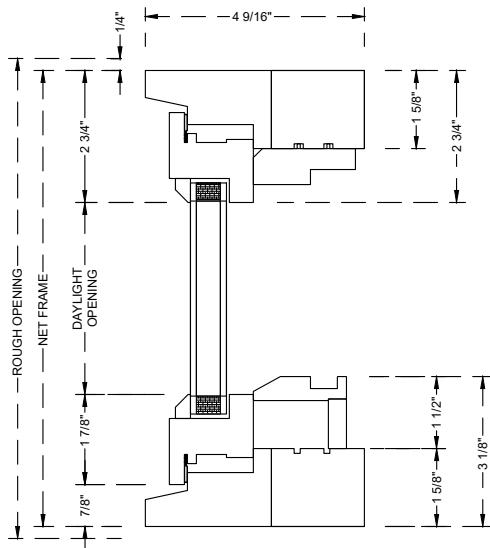

Head Jamb & Sill

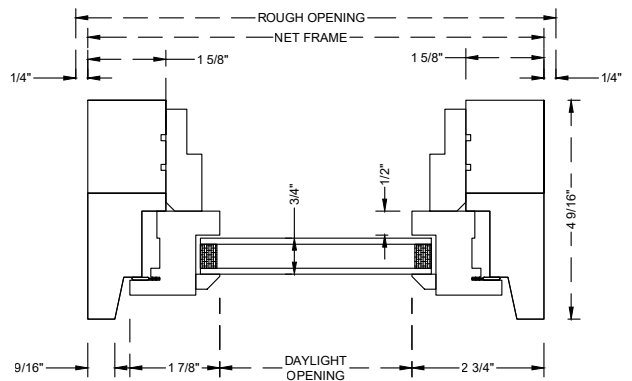

Jambs

# Roto Casement



## Section Details : 4 9/16" Jambs

SCALE: 3" = 1'-0"

Traditional Sash  
1/2" Long Bead Detail

### Operating

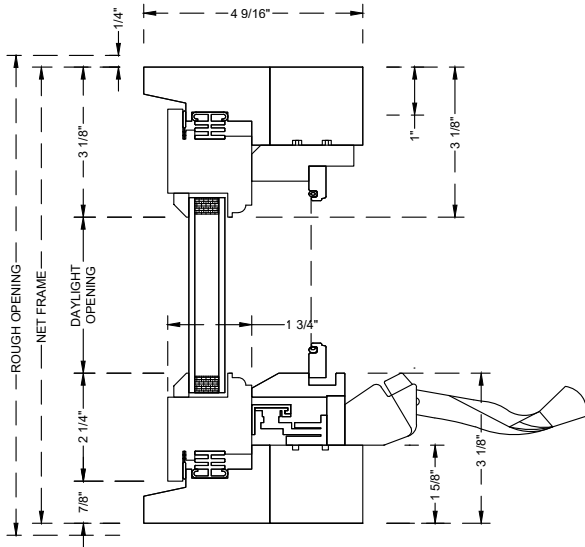

Head Jamb & Sill

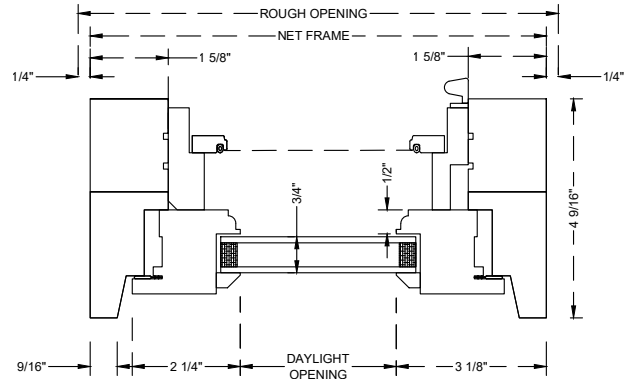

Jambs

### Fixed Sash

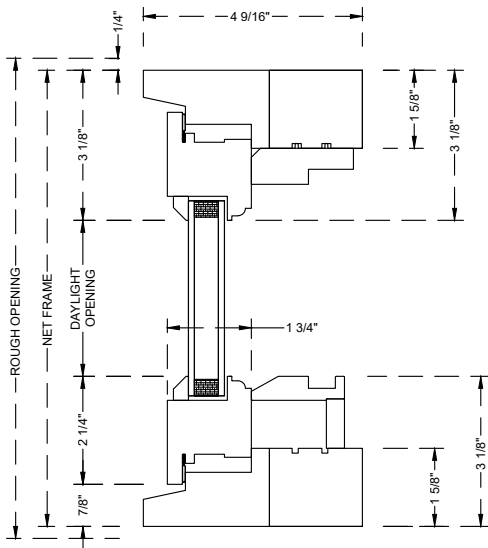

Head Jamb & Sill

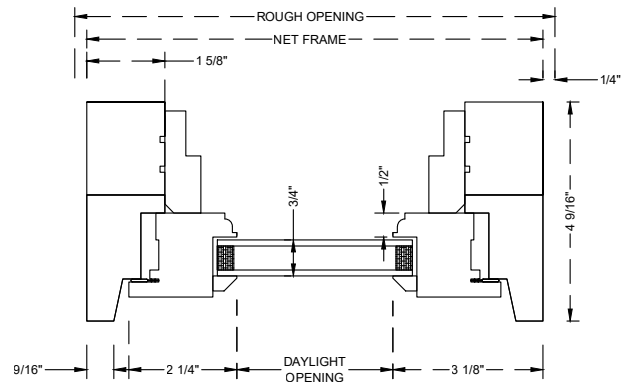

Jambs

Roto Casement

Section Details : Big Bottom Rail Option

SCALE: 3" = 1'-0"

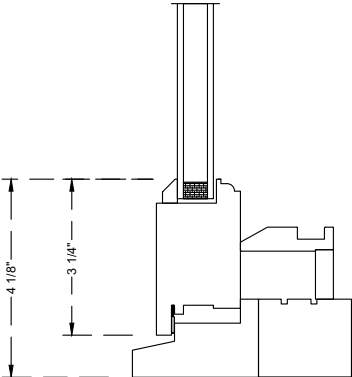

Big Bottom Rail

# Roto Casement

## Section Details : Sash Profiles & SDL Options

SCALE: 3" = 1'-0"

### Sash Profiles & SDL Options

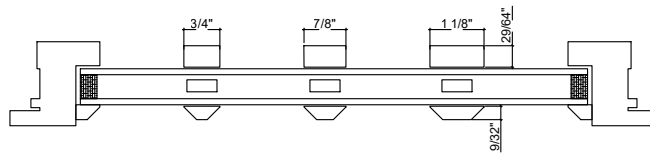

Square Detail Interior/Bevel Bead Exterior

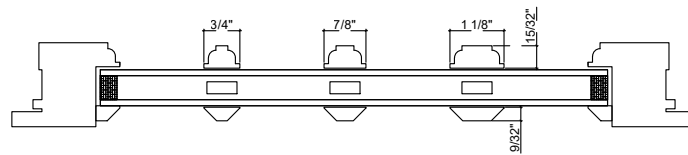

1/2" Long Bead Interior/Bevel Bead Exterior

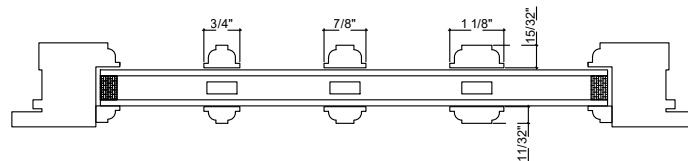

1/2" Long Bead Interior/Long Bead Exterior

# Roto Casement

## Section Details : Mull Sections

SCALE: 3" = 1'-0"

Contemporary Sash  
Square Detail

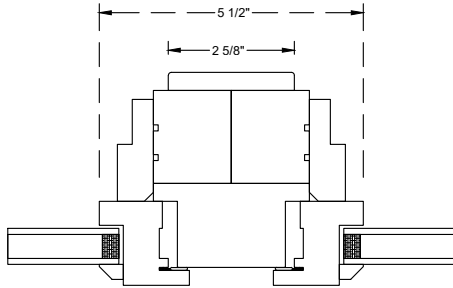

Standard Vertical T-Mull

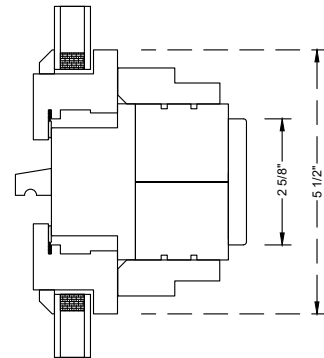

Standard Horizontal T-Mull

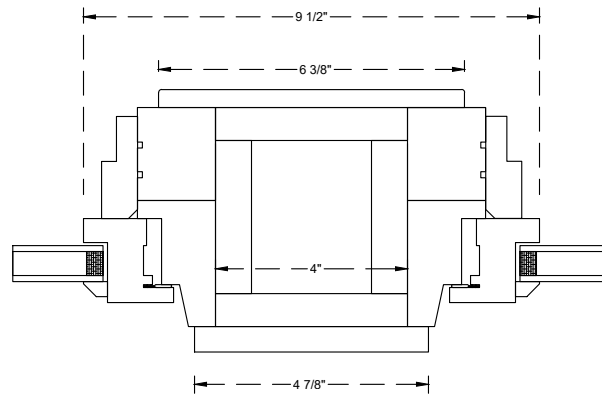

4" Spread Mull

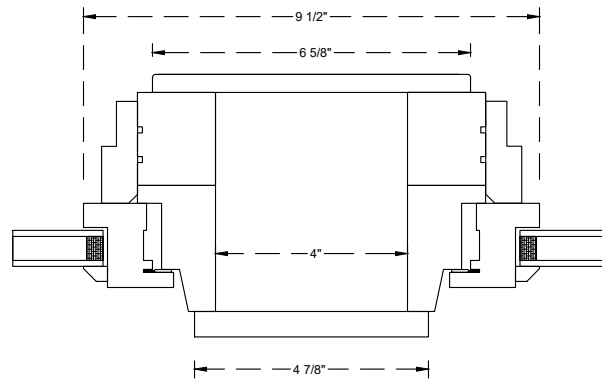

4" Space Mull

# Roto Casement

## Section Details : Sill Options

SCALE: 3" = 1'-0"

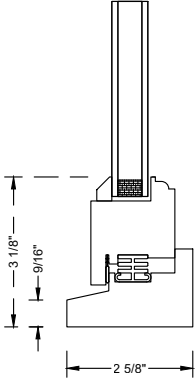

Standard (No Sub Sill)

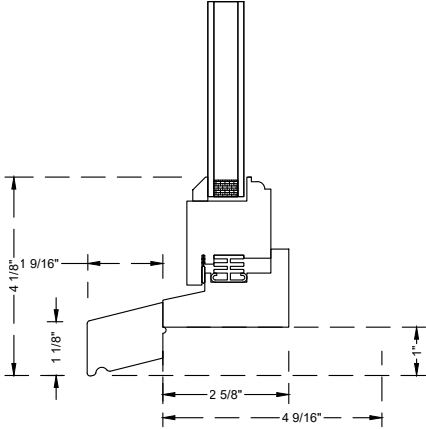

Subsill (2814)

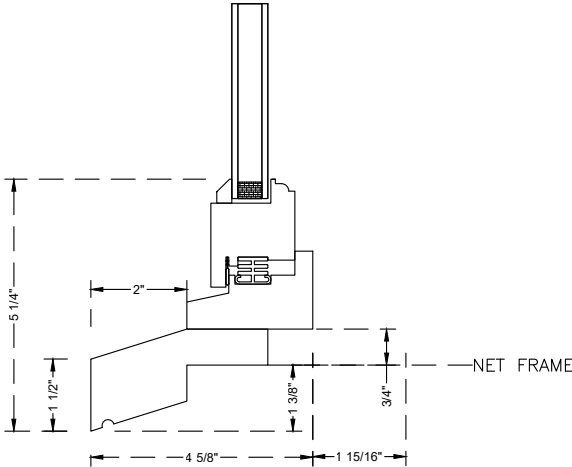

True Subsill (2816)

# Roto Casement

## Section Details : Frame Options

SCALE: 3" = 1'-0"

Standard C2

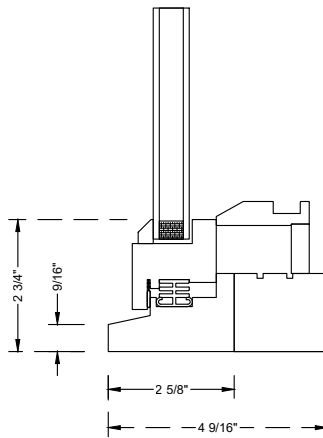

C2 Modified

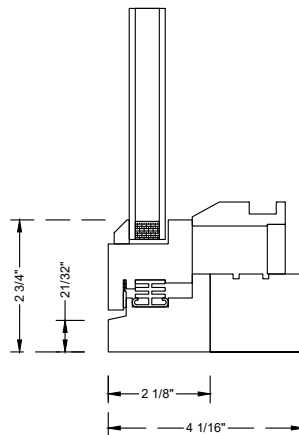



# Roto Casement

## Section Details : Exterior Trim Options

SCALE: 3" = 1'-0"

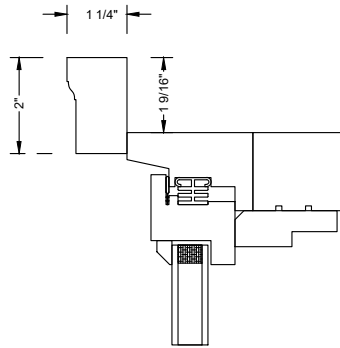

Brickmold Casing

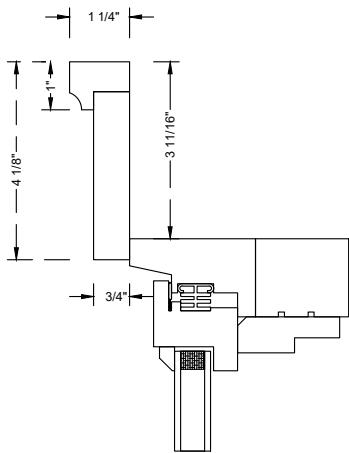

1 x 4 Casing w/ Backband

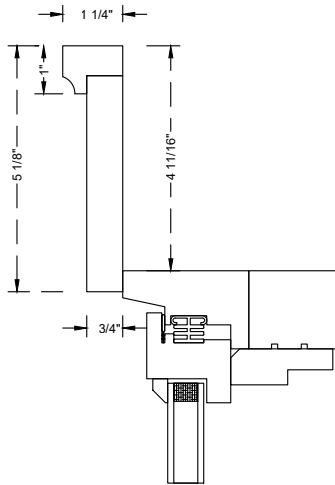

1 x 5 Casing w/ Backband

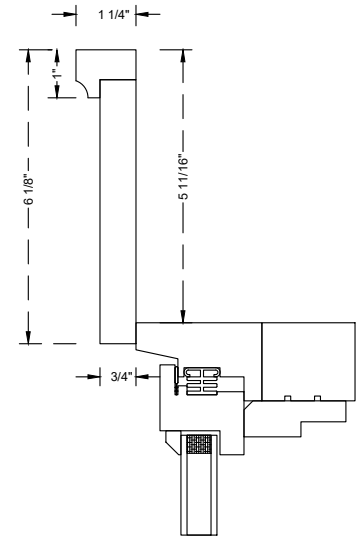

1 x 6 Casing w/ Backband

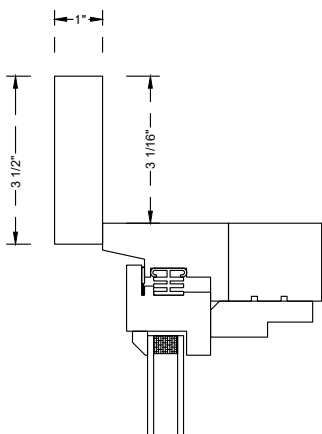

5/4 x 4 Casing

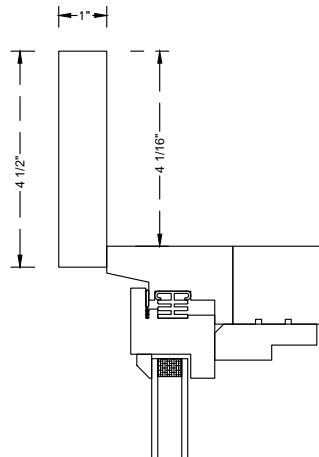

5/4 x 5 Casing

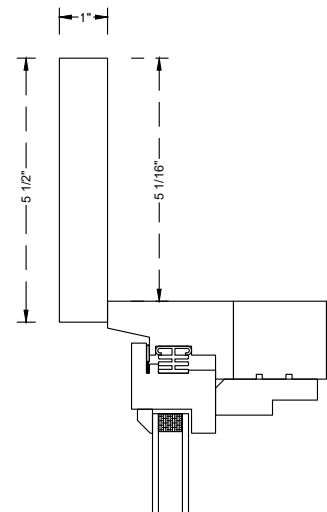

5/4 x 6 Casing

# Roto Casement

## Section Details : Screen Options

SCALE: 3" = 1'-0"

Flat Screen (Standard)

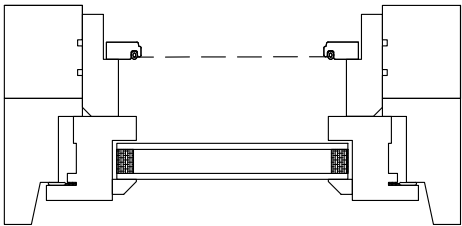
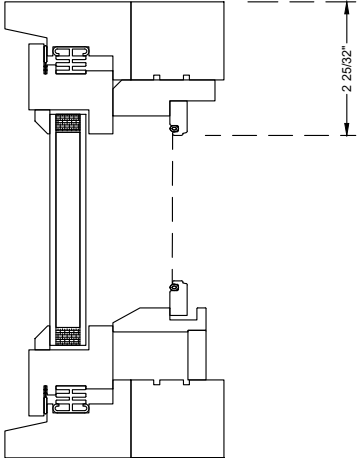

Wood Screen

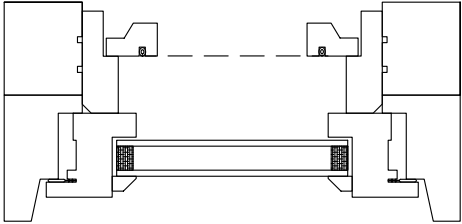
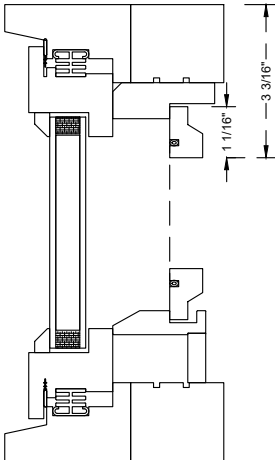

# Roto Casement

## Section Details : Nail Fin Options

SCALE: 3" = 1'-0"

Flush Fin

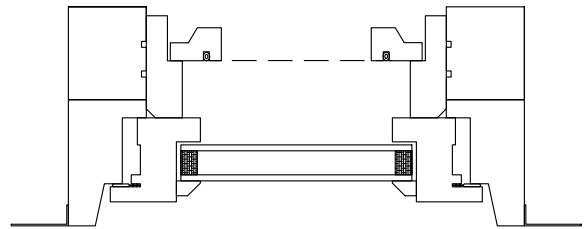
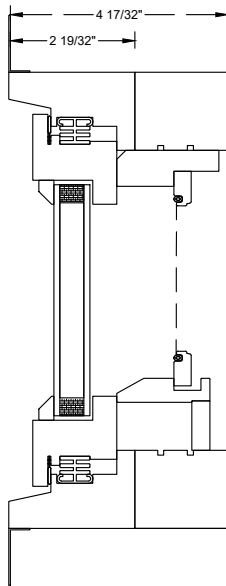

1 3/8 Setback Nail Fin\*  
\*Not compatible with brickmold or subsills

